

Product data sheet

Characteristics

QO120HM

Mini circuit breaker, QO, 20A, 1 pole, 120 VAC, 10 kA, high magnetic, plug in mount

Product availability : Stock - Normally stocked in distribution facility



Main

Product	Miniature circuit-breaker
Range	QO
Current Rating	20 A
Voltage Rating	120 V AC
Mounting Type	Plug-in
Number of Poles	1P
Circuit Breaker Type	High magnetic
Ratings	HACR and Switching Duty rated
Electrical Connection	Pressure plate

Complementary

Interrupt Rating	10 kA 120 V AC 50/60 Hz
Number of Panel Spaces	1
Wire Size	AWG 14...AWG 8 copper or aluminium
Tightening Torque	40.71 lbf.in (4.6 N.m)
Height	3 in (76.20 mm)
Width	0.75 in (19.05 mm)
Depth	2.91 in (73.91 mm)

Environment

Certifications	UL Listed CSA
Ambient Rating	104 °F (40 °C)

* Price is "List Price" and may be subject to a trade discount – check with your local distributor or retailer for actual price.

Ordering and shipping details

Category	00004 - QO,QOT 10-30A 1P;10-60A 2P
Discount Schedule	DE2A
GTIN	00785901400110
Nbr. of units in pkg.	100
Package weight(Lbs)	100 lb(US) (45.36 kg)
Returnability	Yes
Country of origin	MX

Packing Units

Unit Type of Package 1	PCE
Package 1 Height	0.70 in (1.778 cm)
Package 1 width	2.70 in (6.858 cm)
Package 1 Length	3.00 in (7.62 cm)
Unit Type of Package 2	BB1
Number of Units in Package 2	10
Package 2 Weight	2.76 lb(US) (1.252 kg)
Package 2 Height	3.30 in (8.382 cm)
Package 2 width	2.70 in (6.858 cm)
Package 2 Length	7.70 in (19.558 cm)
Unit Type of Package 3	CAR
Number of Units in Package 3	100
Package 3 Weight	28.26 lb(US) (12.819 kg)
Package 3 Height	8.30 in (21.082 cm)
Package 3 width	6.90 in (17.526 cm)
Package 3 Length	17.20 in (43.688 cm)

Offer Sustainability

Sustainable offer status	Green Premium product
REACH Regulation	REACH Declaration
REACH free of SVHC	Yes
EU RoHS Directive	Compliant EU RoHS Declaration
Toxic heavy metal free	Yes
Mercury free	Yes
RoHS exemption information	Yes
China RoHS Regulation	China RoHS declaration Pro-active China RoHS declaration (out of China RoHS legal scope)
Environmental Disclosure	Product Environmental Profile
Halogen content performance	Halogen free product

Contractual warranty

Warranty	18 months
----------	-----------

Dimensions

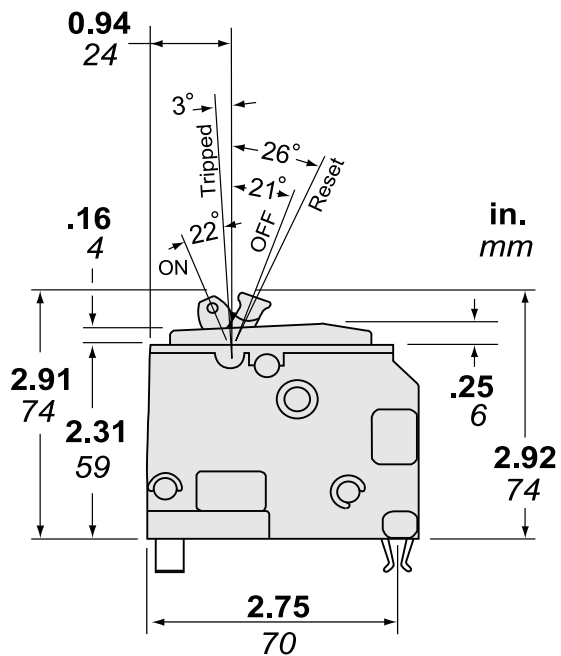
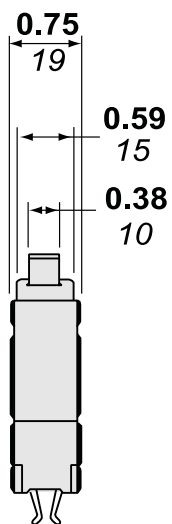
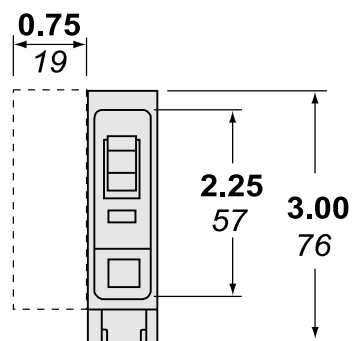

Dimensions are approximate. Refer to technical documentation for additional detail.